

# 2024 GPSRR Approach Paper

November 2023

National Electricity Rules





# Important notice

## Purpose

AEMO has prepared the 2024 General Power System Risk Review (2024 GPSRR) approach paper under clause 5.20A.2(c)(3) of the National Electricity Rules.

## Disclaimer

This document or the information in it may be subsequently updated or amended. This document does not constitute legal, technical or business advice, and should not be relied on as a substitute for obtaining detailed advice about the National Electricity Law, the National Electricity Rules, or any other applicable laws, procedures or policies. AEMO has made reasonable efforts to ensure the quality of the information in this document but cannot guarantee its accuracy or completeness.

Accordingly, to the maximum extent permitted by law, AEMO and its officers, employees and consultants involved in the preparation of this document:

- make no representation or warranty, express or implied, as to the currency, accuracy, reliability or completeness of the information in this document; and
- are not liable (whether by reason of negligence or otherwise) for any statements or representations in this document, or any omissions from it, or for any use or reliance on the information in it.

## Copyright

© 2023 Australian Energy Market Operator Limited. The material in this publication may be used in accordance with the [copyright permissions on AEMO's website](#).

## Version control

Version	Release date	Changes
1.0	22/08/2023	Initial release for consultation
2.0	17/11/2023	Final approach paper following consultation



# Contents

1	Introduction	5
1.1	Purpose and invitation for submissions	5
1.2	Stakeholder consultation and update	5
1.3	Priority risks	6
1.4	2024 GPSRR delivery plan	6
2	Study background	8
2.1	Evolving power system risks	8
2.2	Network development path	8
3	Priority risks to be assessed	10
3.1	Priority risk identification factors	10
3.2	NSP consultation	10
3.3	Review of relevant system events since the 2023 GPSRR	12
3.4	Initial risk categorisation	12
3.5	Contingency risks to be assessed	13
3.6	Other review tasks	17
4	Models and study case scenarios development	19
4.1	Monitored parameters	19
4.2	Study software	19
4.3	Network model	20
4.4	Primary frequency response (PFR) governor models	21
4.5	Frequency control ancillary services (FCAS) response	22
4.6	Special protection scheme (SPS) models	23
4.7	Emergency frequency control scheme (EFCS) models	23
4.8	DER/DPV models	24
4.9	Load models	24
4.10	Data to assess future scenarios	25
4.11	Forecasting assumptions	25
4.12	2024 GPSRR model sources	26
5	Risk Cost assessment methodology	27
6	Consultation approach	28
	Abbreviations	29



## Tables

Table 1	Committed, anticipated and actionable major transmission projects to June 2029	9
Table 2	Risk categories	11
Table 3	Likelihood descriptions	11
Table 4	Consequence descriptions	12
Table 5	Risk matrix	12
Table 6	Risk 1 overview	14
Table 7	Risk 2 overview	16
Table 8	Risk 3 overview	16
Table 9	UFLS contingencies	17
Table 10	Special protection scheme models to be considered	23

## Figures

Figure 1	High-level project schedule	6
Figure 2	Simplified single line diagram of Loy Yang power station – circuit breaker statuses post fault clearance	15
Figure 3	The CMLD model structure and the implementation of the DERAEMO1 model	24
Figure 4	2024 GPSRR model sources	26

# 1 Introduction

## 1.1 Purpose and invitation for submissions

In accordance with rule 5.20A of the National Electricity Rules (NER), AEMO is required to undertake a General Power System Risk Review (GPSRR) and prepare a GPSRR report for the National Electricity Market (NEM) at least annually. The 2023 GPSRR<sup>1</sup> was published on 10 July 2023.

AEMO has commenced the 2024 GPSRR and plans to publish the 2024 GPSRR report by 31 July 2024.

The purpose of the GPSRR is to review:

- A prioritised set of risks comprising contingency events and other events and conditions that could lead to cascading outages or major supply disruptions.
- The current arrangements for managing the identified priority risks and options for their future management.
- The arrangements for management of existing protected events and consideration of any changes or revocation.
- The performance of existing emergency frequency control schemes (EFCS) and the need for any modifications.

The GPSRR will also summarise other key risk assessment activities that AEMO is currently undertaking.

This document is the final approach paper published by AEMO following consultation on:

- The prioritised set of risks (contingency events and other events and conditions that could lead to cascading outages or major supply disruptions) that AEMO will review in the 2024 GPSRR (see Section 3).
- The approach, methodologies, information, and assumptions AEMO will use in assessing the priority risks (see Sections 2, 3, 4 and 5).
- How AEMO proposes to consult with relevant parties throughout the 2024 GPSRR (see Section 6).

For completeness, the approach paper also includes a high-level description of the work planned to address the other core elements of the GPSRR.

## 1.2 Stakeholder consultation and update

AEMO prepared this approach paper with the benefit of input from network service providers (NSPs) on potential priority risks, and their initial feedback on the assessment approach. In addition to consultation with NSPs, AEMO undertook a review of potential priority risk candidates based on operational experience, recent power system events and anticipated power system changes.

In August 2023, AEMO issued an initial version of the approach paper for consultation, in accordance with NER 5.20A.2(c)(3). Based on stakeholder feedback received and additional AEMO review, AEMO has modified some aspects of this final version of the approach paper. AEMO has published a separate report<sup>2</sup> on relevant

<sup>1</sup> See <https://aemo.com.au/en/energy-systems/electricity/national-electricity-market-nem/system-operations/general-power-system-risk-review>.

<sup>2</sup> 2024 GPSRR approach consultation report, at <https://aemo.com.au/consultations/current-and-closed-consultations/2024-gpsr-review>.

stakeholder feedback received, AEMO’s responses, and the reasons for changes made to this final approach paper.

### 1.3 Priority risks

AEMO has selected the following three priority risks for assessment in the 2024 GPSRR:

- Circuit breaker failure (CBF) event in Latrobe Valley leading to trip of multiple large generating units and Basslink instability.
- Non-credible loss of double circuit HumeLink 500 kV lines.
- Under frequency load shedding (UFLS) screening studies, including the contingencies specified in Table 9 (in Section 3.5).

Further details on these priority risks and the methodology used to identify them are included in Section 3. The risk assessment approach will also be described in further detail in the 2024 GPSRR.

### 1.4 2024 GPSRR delivery plan

#### 1.4.1 Project schedule

Figure 1 shows the high-level 2024 GPSRR project schedule for key activities, including the approach paper development and consultation.

Figure 1 High-level project schedule

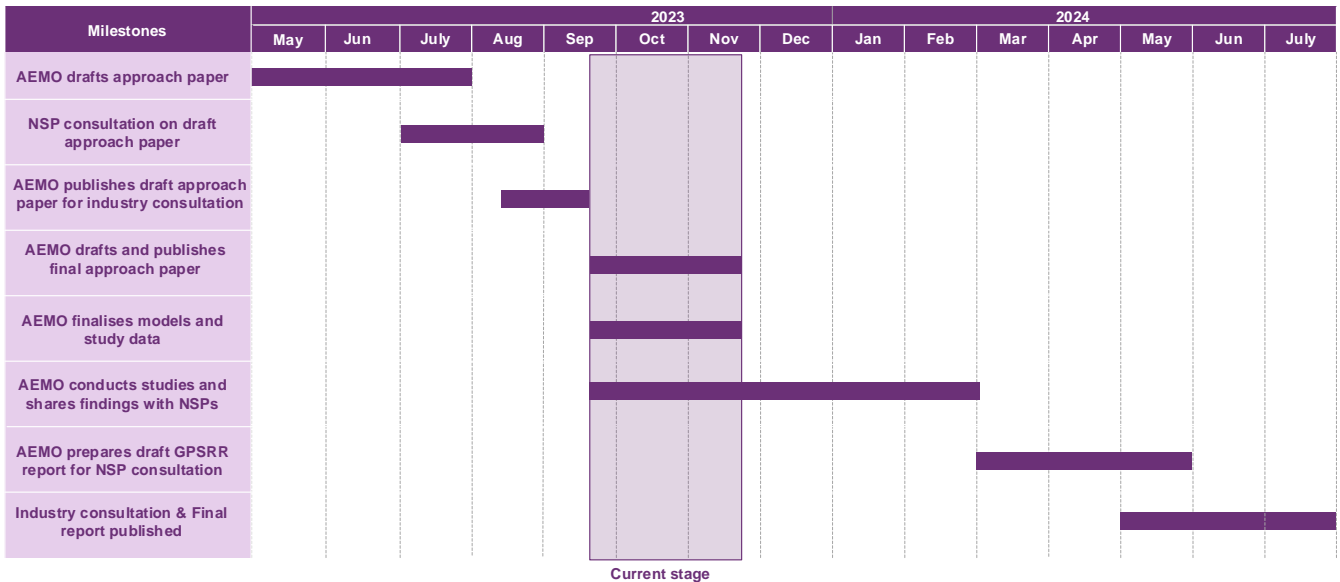

#### 1.4.2 Project critical activities

To deliver a high standard review report as planned by July 2024, successful completion of the following key activities within the planned period is considered critical:



**Completed**

- Collation of all preliminary models and data for the study<sup>3</sup> (August 2023).
- Submissions on approach paper close (20 September 2023).

**Planned**

- On completion of the studies, AEMO to share the findings with NSPs (January 2024 to March 2024).
- Draft 2024 GPSRR report published for industry feedback (May 2024).
- Publication of final GPSRR report (by 31 July 2024).

---

<sup>3</sup> Or application of appropriate and agreed modelling assumptions.

## 2 Study background

### 2.1 Evolving power system risks

As a part of the GPSRR, AEMO will assess the risks of the future power system. These studies will consider system changes including:

- Operational loads.
- Distributed photovoltaics (DPV) and inverter-based resources (IBR) penetration.
- Changes in operation/retirement of existing synchronous generators.
- Addition, upgrade, or decommissioning of special protection schemes (SPSs).
- Major network augmentations, including renewable energy zone (REZ) developments.

### 2.2 Network development path

The 2022 *Integrated System Plan* (ISP) and its optimal development path support Australia's complex and rapid energy transformation towards net zero emissions. The 2022 ISP *Step Change* scenario is currently considered by energy industry stakeholders to be the most likely scenario to play out<sup>4</sup>, so forecasting data from the 2022 ISP *Step Change* scenario will be used in the 2024 GPSRR for future projections. Note that the future dispatch scenarios selected will be reviewed based on the latest ISP information available following the publication of the Draft 2024 ISP<sup>5</sup> by 15 December 2023. The impact of any ISP projects or major changes to state-based schemes will also be considered if they are identified in the Draft 2024 ISP. If significant differences are identified in the Draft 2024 ISP, AEMO may conduct additional study sensitivities.

Consistent with the Transmission Augmentation Information workbook published in July 2023<sup>6</sup>, Table 1 displays each of the major ISP committed, anticipated and actionable projects in the next five years.

The projects listed in Table 1 were considered to be major augmentations that could impact the contingencies to be studied in the 2024 GPSRR and as a result, these projects will be considered in the assessment of future network conditions. Announced potential closures of power stations such as Eraring Power Station (2025) and Yallourn Power Station (2028) will also be considered in future studies. Minor augmentations that are determined to not have a significant impact on the contingencies are not intended to be included.

<sup>4</sup> See Section 2.3 of the 2022 ISP, at <https://aemo.com.au/-/media/files/major-publications/isp/2022/2022-documents/2022-integrated-system-plan-isp.pdf?la=en>.

<sup>5</sup> See <https://aemo.com.au/en/energy-systems/major-publications/integrated-system-plan-isp/2024-integrated-system-plan-isp>.

<sup>6</sup> See <https://aemo.com.au/en/energy-systems/electricity/national-electricity-market-nem/nem-forecasting-and-planning/forecasting-and-planning-data/transmission-augmentation-information>.



Table 1 Committed, anticipated and actionable major transmission projects to June 2029

Project	Capacity release date <sup>A</sup>	Status
<b>Victoria – New South Wales Interconnector (VNI) Minor</b>	July 2023	Completed
<b>Eyre Peninsula Link</b>	July 2023	Completed
<b>Queensland – New Wales Interconnector (QNI) Minor</b>	Mid-2023 <sup>B</sup>	Committed
<b>Northern Queensland Renewable Energy Zone (QREZ) Stage 1</b>	November 2023	Committed
<b>Central West Orana REZ Transmission Link</b>	September-2027	Anticipated
<b>Project EnergyConnect</b>	July 2026 <sup>C</sup>	Committed
<b>Western Renewables Link</b>	July 2027	Anticipated
<b>HumeLink</b>	July 2026	ISP Actionable Project
<b>Sydney Ring</b>	December 2027	NSW Actionable Project <sup>D</sup>
<b>New England REZ Transmission Link</b>	September 2028	NSW Actionable Project <sup>D</sup>

A. This field provides an indication of timing for the full capacity of the project to become available in the NEM. The capacity release of the project requires the successful completion of inter-network testing where necessary, which may require certain conditions in the NEM.

B. Some capacity for this project has already been released. Further capacity release expected over the coming months subject to market conditions for further inter-network testing.

C. This projected delivery date for Project EnergyConnect refers to full capacity available following completion of inter-regional testing.

D. Sydney Ring and New England REZ Transmission Link are actionable under the *Electricity Infrastructure Investment Act 2020* (NSW) rather than the ISP framework.

## 3 Priority risks to be assessed

### 3.1 Priority risk identification factors

When identifying contingency events or other events or conditions for assessment as priority risks in the 2024 GPSRR, AEMO had regard to the following key factors and sources of information<sup>7</sup>:

- The severity of the likely power system security outcomes if the events or conditions occur.
- The likelihood of occurrence.
- Whether technically and (on preliminary assessment) economically feasible management options are likely to be available.
- Information provided by NSPs and Jurisdictional System Security Coordinators (JSSCs).
- If applicable, any findings or analysis from previous event investigation or reporting.
- The scope of work that is achievable within the publication timeframe of the final 2024 GPSRR report (by 31 July 2024).

Other relevant factors are outlined in Section 3.4.

### 3.2 NSP consultation

To identify candidate events and conditions for priority assessment, AEMO requested each transmission network service provider (TNSP) and distribution network service provider (DNSP) to share with AEMO any:

- Priority contingency events that may result in uncontrolled changes in frequency leading to cascading outages, or major supply disruptions.
- Other events or conditions that would likely lead to cascading outages or supply disruptions.

To aid the collection and assessment of this information, AEMO asked NSPs to complete a risk assessment document, with the following information in relation to the nominated event or condition (as applicable):

1. A high-level description of the risk or non-credible contingency event that could lead to cascading outages or major supply disruptions.
2. The primary risk category (the primary risk categories defined for this risk assessment are in Table 2).
3. A description of which network elements would trip if the event occurred.
4. A description of which protection elements are likely to operate if the event occurred.
5. Details of any historical occurrences (or near misses).
6. Details of any existing control or risk management strategies.
7. Details of any planned augmentations that may affect the event or risk.
8. An outline of the likely consequences of the event.

---

<sup>7</sup> As required by NER 5.20A.1(a1).

9. Whether the event has the potential to cause cascading failures.
10. Details of any previous studies or assessments of the event.
11. The likelihood of the event occurring (Table 3 below outlines how likelihood is categorised for this risk assessment). A likelihood rating from 1 to 5 was assigned based on the likelihood category specified, where 1 was the lowest likelihood and 5 was the highest likelihood.
12. Consequence (Table 4 below outlines how consequence is categorised for this risk assessment). A consequence rating from 1 to 5 was assigned based on the consequence category specified, where 1 was the lowest consequence, and 5 was the highest consequence.

An inherent risk rating was then calculated based on the likelihood and consequence of the event. This was calculated as the product of the likelihood rating and the consequence rating (the outcomes of this calculation are as per the matrix in Table 5).

In addition to consultation with NSPs, AEMO undertook a review of potential priority risk candidates based on operational experience, recent power system events and anticipated power system changes (such as REZ developments).

Section 3.4 outlines how AEMO has categorised the information received on key contingencies and risks for the 2024 GPSRR.

**Table 2 Risk categories**

Risk category	Description
<b>Frequency risk</b>	Any incident caused by unacceptable frequency conditions on the power system.
<b>Voltage risk</b>	Any incident caused by unacceptable voltage conditions on the power system.
<b>Inertia risk</b>	Any incident caused by a lack of system inertia; this lack of inertia could lead to a rate of change of frequency (RoCoF) event.
<b>System strength services risk</b>	Any incident caused by a lack of system strength services. This lack of availability could lead to system instability and/or protection maloperations.
<b>Distributed energy risks</b>	Any incident which is caused by distributed energy resources. This could be distributed energy resources (DER) disconnecting during a fault and leading to an excessive frequency change, or it could be an incident directly caused by the DER in an area.
<b>SPS risks</b>	Any incident which is caused by unexpected interactions or mal operations of SPS systems.
<b>Cyber security risks</b>	Any incident which is caused by a malicious cyber attack.
<b>IT risks</b>	Any incident which is caused by an IT failure (not a cyber attack).
<b>Weather related risks</b>	Any incident caused by weather impacts such as flooding, lightning and storms.
<b>Other</b>	Any incident not categorised above.

**Table 3 Likelihood descriptions**

Likelihood	Annual probability	Qualitative description
<b>Almost certain</b>	>90%	Will occur in most circumstances; statistical record of several occurrences.
<b>Likely</b>	51% - 90%	Can be expected to occur in most circumstances; statistical record of at least two or more occurrences.
<b>Possible</b>	11% - 50%	May occur, but not expected in most circumstances; statistical record of at least one occurrence.
<b>Unlikely</b>	1% - 10%	Conceivable but unlikely to occur in any given year; may or may not have statistical history of occurrence.
<b>Rare</b>	<1%	Will only occur in exceptional circumstances; no history of occurrence.

**Table 4 Consequence descriptions**

Consequence	Market and system impact
<b>Extreme</b>	Loss of supply to multiple states for any duration. Market suspension of multiple markets for a prolonged period.
<b>Major</b>	Loss of supply to a large portion of a state, for any duration. Market suspension in one jurisdiction or market for a short period.
<b>Moderate</b>	Localised/minimal loss of supply in a state. Market(s) in administered state or material scheduling error.
<b>Minor</b>	Intervention required to maintain supply. Immaterial scheduling error (below dispute threshold).
<b>Immaterial</b>	No restriction of supply. No disruption to markets.

**Table 5 Risk matrix**

	Almost certain	Likely	Possible	Unlikely	Rare
<b>Extreme</b>	25	20	15	10	5
<b>Major</b>	20	16	12	8	4
<b>Moderate</b>	15	12	9	6	3
<b>Minor</b>	10	8	6	4	2
<b>Immaterial</b>	5	4	3	2	1

### 3.3 Review of relevant system events since the 2023 GPSRR

AEMO will identify all relevant system events that occurred in financial year (FY) 2022-23 in the 2024 GPSRR report. AEMO will consider the findings and recommendations from these incidents in its 2024 GPSRR.

### 3.4 Initial risk categorisation

AEMO considered all the risks identified as part of the NSP consultation exercise and organised them into three broad categories:

- Contingencies and risks where AEMO has concluded there are adequate controls in place or are considered to be a lower priority compared to other risks chosen for the 2024 GPSRR. AEMO will not consider these risks as part of the 2024 GPSRR. For example, these contingencies or risks may have:
  - Reclassification procedures to identify and control risk.
  - Tools in place to monitor and alert control room operators.
  - Automatic protection which operates to limit the impact of the contingency.
  - Been analysed/managed as part of normal NSP processes.
- Contingencies or risks where the impact is difficult to define and study, that are outside the GPSRR scope, or that could be studied but are deemed to have a lower impact and consequence than other contingencies. AEMO will discuss these in the report but does not plan to carry out additional studies. AEMO may also include

additional commentary regarding whether systems and tools are fit-for-purpose to manage these risks<sup>8</sup>.

Examples include:

- Power system resilience and restoration.
  - Fuel diversity/supply interruptions.
  - System restart with a transitioning power system.
  - Aggregated fast frequency response of battery energy storage systems (BESS).
  - Future management of maximum contingency sizes.
  - Increasing voltage excursions due to lack of dynamic system reactive reserves.
  - Weather-related issues including space weather related risks.
  - Market/supply scarcity issues.
  - Information technology (IT)/supervisory control and data acquisition (SCADA) failure.
  - Cyber-related risks.
  - Communication-related risks.
  - Control/protection system interaction risks.
  - Contingencies with a lower inherent risk rating (see Table 5).
  - Insufficient generation available for dispatch due to various reasons.
  - Future contingencies with great uncertainties in detailed design/parameters.
  - Interconnector drift.
- High consequence contingencies or risks without adequate protection or an adequate process to manage the event. Risks in this category are candidates for review as part of the 2024 GPSRR. These risks were further assessed by AEMO to identify whether they should be prioritised for study in this year’s review. Where risks were not selected for study, AEMO may consider them in future reviews or refer to relevant work underway by NSPs and/or AEMO to assess/control the risk.

### 3.5 Contingency risks to be assessed

AEMO has selected key contingencies and other events or conditions from the candidate list as priority risks for assessment. The risks listed below were selected for the 2024 GPSRR based on:

- The likely power system impact of the contingency and its estimated probability of occurrence.
- Details of any review/work previously completed to understand or manage the contingency/risk.
- Any changes to power system conditions or other factors which may have materially changed the risk profile of a contingency/risk.
- Whether a contingency or risk has been reviewed previously as part of AEMO’s risk review process (that is, reviewed under a previous PSFRR or GPSRR).

<sup>8</sup> See <https://aemo.com.au/initiatives/major-programs/operations-technology-roadmap>.

Priority risks were selected for study against operating conditions set 1-2 years in the future (FY 2023-24 to FY 2024-25), or five years in the future (in FY 2028-29). Further details on the snapshot selection process for the priority risks will be discussed in the 2024 GPSRR report.

### Risks to be assessed in the 1-2-year time horizon

The circuit breaker fail contingency detailed in Table 6 was identified as a potential existing risk to the system due to its impact on system strength at Hazelwood. Consistent with the System Strength Requirements Methodology<sup>9</sup>, to assess contingencies relating to system strength issues or fault-ride-through (FRT) behaviours of IBR, AEMO will conduct electromagnetic transient (EMT) analysis using the four state NEM Power System Computer Aided Design (PSCAD™) version 5 model. This model is made up of the four NEM mainland regions of New South Wales, Queensland, South Australia, and Victoria, and contains all the transmission networks elements, as well as key distribution network elements for each of these states.

The use of EMT analysis is preferred for power system stability studies to identify system strength issues, such as control interactions between IBR, in time horizons where network and generator models are precise (such as 1-2 years). However, EMT simulations are not fit-for-purpose in long-term planning studies because their accuracy is limited by the use of generic models for conceptual projects. Hence, the circuit breaker failure risk detailed below will be assessed in the 1-2-year time horizon.

**Table 6 Risk 1 overview**

Contingency	Circuit breaker failure (CBF) event in Latrobe Valley leading to trip of multiple large generating units and Basslink instability
<b>Description</b>	These studies will include the assessment of numerous different non-credible events around the Latrobe Valley that could lead to the loss of multiple large generating units. An example of such an event is a fault on the Loy Yang B unit 2 transformer followed by the failure of the single bus coupler circuit breaker that connects the 500 kilovolts (kV) No. 3 bus and Loy Yang B unit 2. This would result in the circuit breaker fail protection clearing the No. 3 bus, disconnecting both Loy Yang B units as well as Valley Power Station. This could result in the loss of up to approximately 1,300 MW of generation in Victoria. A simplified single line diagram of the Loy Yang power station and the relevant circuit breakers is shown in Figure 2 below.
<b>Operating conditions</b>	Consistent with the System Strength Requirements Methodology, near term (1-2-year horizon) including committed generation where agreed generator models (accepted by the relevant Connecting NSP and AEMO) are available.
<b>Likelihood</b>	Unlikely (1% to 10% annual probability of a CBF event leading to loss of multiple generating units. A CBF event in Latrobe Valley is a less than 1% annual probability, but is used as a case study for a NEM-wide issue).
<b>Impact</b>	Major (loss of supply to a large portion of a state, for any duration). <ul style="list-style-type: none"> <li>This generation contingency is likely to impact system strength and IBR FRT around Hazelwood.</li> <li>Generation loss, frequency excursions, UFLS operation.</li> </ul>
<b>Risk conditions</b>	<ul style="list-style-type: none"> <li>Minimum Victoria and NEM system strength.</li> <li>High Basslink flows from Tasmania to Victoria, or from Victoria to Tasmania.</li> <li>Shallow fault of 0.7 p.u. in Victoria.</li> <li>Minimum demand.</li> </ul>
<b>Existing management strategies</b>	Minimum system strength fault level requirements.
<b>Potential solutions</b>	Modification to system strength requirements, circuit breaker configuration, or implementation of an SPS.
<b>Study software</b>	PSCAD™
<b>Risk raised by</b>	AEMO

<sup>9</sup>See [https://aemo.com.au/-/media/files/electricity/nem/security\\_and\\_reliability/system-strength-requirements/system-strength-requirements-methodology.pdf?la=en](https://aemo.com.au/-/media/files/electricity/nem/security_and_reliability/system-strength-requirements/system-strength-requirements-methodology.pdf?la=en).

Figure 2 Simplified single line diagram of Loy Yang power station – circuit breaker statuses post fault clearance

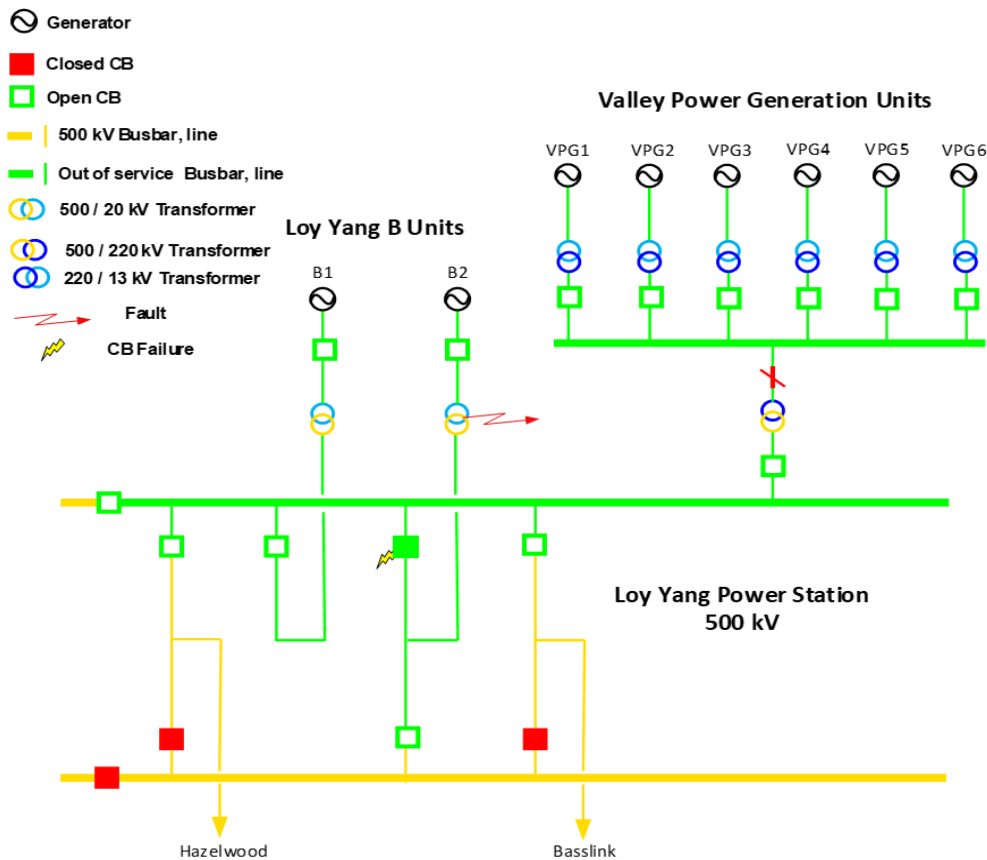

### Risks to be assessed against FY 2028-29 projected operating conditions

Contingencies to be studied under future FY 2028-29 operating conditions were selected on the basis that the risk they pose to the power system is predicted to become more significant in the future due to projected changes in the power system. The process to identify these priority risks for future studies also considered the timeframe required for the implementation of possible remedial actions and any planned network augmentations that may affect the risk likelihood or consequence.

The 2028-29 future studies will consider the ISP projected levels of demand, generation, and distributed energy resources (DER)/DPV. In addition, updated UFLS/over frequency generation shedding (OFGS) settings, planned network augmentations/upgrades, and corresponding protection schemes will be considered in the study.

The risks selected for future studies are likely to be impacted by forecast changes to operating conditions in the NEM. Therefore, the risks detailed in Table 7 and Table 8 will be assessed against FY 2028-29 operating conditions.

As noted in Table 7, Transgrid is evaluating risks associated with the non-credible loss of HumeLink double circuit 500 kilovolts (kV) lines. In accordance with NER S5.1.8, Transgrid has undertaken initial studies to assess the impact on Transgrid’s network and the feasibility of an SPS to manage this non-credible event. AEMO will review and input this evaluation when consulted under S5.1.8 and present the results as part of the GPSRR.

**Table 7 Risk 2 overview**

Contingency	Non-credible loss of double circuit HumeLink 500 kV lines
<b>Likelihood</b>	Unlikely (1% to 10% annual probability)
<b>Impact</b>	<p>Extreme (loss of supply to multiple states for any duration. Market suspension of multiple markets for a prolonged period).</p> <ul style="list-style-type: none"> <li>At high flows over HumeLink, a double circuit contingency will result in thermal overloads of parallel 330 kV and 132 kV lines, along with generation trip and frequency risks.</li> <li>Potential to result in cascading outages, voltage collapse and loss of supply to multiple states.</li> </ul>
<b>Risk conditions</b>	<ul style="list-style-type: none"> <li>High northward or southward flows in Gugaa – Bannaby, Maragle – Bannaby and Gugaa – Maragle 500 kV lines.</li> <li>High and low NEM demand.</li> <li>High IBR generation in New South Wales.</li> <li>High QNI Queensland export and high South Australian export.</li> <li>High DPV in all NEM regions.</li> <li>Low synchronous generation/inertia</li> <li>Low UFLS in all NEM regions.</li> </ul>
<b>Existing management strategies</b>	Surge arresters for transmission towers, single-phase auto reclose, reclassification for bushfire conditions, UFLS.
<b>Potential solutions</b>	Combination of reclassification and an SPS.
<b>Study software</b>	Power System Simulation for Engineering (PSS®E) (full NEM model)
<b>Risk raised by</b>	Transgrid

A significant focus of the 2024 GPSRR is the evaluation of emergency under frequency response (EUFR)-related risks across the mainland NEM. To evaluate the adequacy of UFLS and EUFR in the current and future system, the UFLS screening studies (Risk 3) detailed in Table 8 will be assessed against both historical FY 2022-23 and future FY 2028-29 operating conditions using a simplified PSS®E NEM network model.

**Table 8 Risk 3 overview**

Contingency	UFLS screening studies
<b>Description</b>	<p>Screening studies assessing UFLS adequacy with current bands using simplified model for historical operating conditions (FY 2022-23) and five years ahead (FY 2028-29).</p> <p>With reference to NER 4.3.1(k)(2), studies will include analysis of NEM intact and separation scenarios for a range of significant multiple generation contingencies.</p>
<b>Impact</b>	<p>Major (loss of supply to a large portion of a state, for any duration).</p> <ul style="list-style-type: none"> <li>Potential for cascading failures if inadequate UFLS for non-credible contingencies.</li> </ul>
<b>Risk conditions</b>	<p>Various, including:</p> <ul style="list-style-type: none"> <li>High DPV.</li> <li>Low demand.</li> <li>Low synchronous/low inertia.</li> <li>High IBR.</li> <li>Generation contingency size.</li> </ul>
<b>Existing management strategies</b>	UFLS
<b>Potential solutions</b>	Revision of UFLS settings.
<b>Study software</b>	PSS®E (simplified NEM model)
<b>Risk raised by</b>	AEMO

A. Under NER 4.3.1(k)(2), AEMO must ensure appropriate levels of contingency capacity reserves are available to arrest the impacts of a range of significant multiple contingency events (affecting up to 60% of the total power system load) or protected events to allow a prompt restoration or recovery of power system security, taking into account under-frequency-initiated load shedding capability provided under connection agreements, by EFCS or otherwise.



The contingencies being assessed in the UFLS screening studies are outlined in Table 9 and are consistent with those considered in previous UFLS reviews. The multiple contingency events cover a range of contingency sizes and inertia combinations based on existing generation as well as the loss of potential future REZ generation across the NEM. Separation events will also be considered as part of these screening studies.

**Table 9 UFLS contingencies**

Contingency no.	Approximate contingency size (MW)	Approximate contingency inertia (MW.s)	Description
1	750	2,000	Kogan Creek trip. A credible contingency used only for reference.
2	1,400	5,000	Equivalent to: Mt Piper plant trip
3	2,200	9,000	Equivalent to: Loy Yang A plant trip
4	3,000	12,500	Equivalent to: Loy Yang A trip + TIPS B plants trip
5	3,600	12,000	Equivalent to: Eraring + Kogan Creek plants trip
6	4,400	17,500	Equivalent to: Loy Yang A trip + Mt Piper + TIPS B plants trip
7	5,200	19,500	Equivalent to: Loy Yang A + Torrens Island B + Mt Piper + Kogan Creek plants trip
8	3,300	12,400	Bayswater + Mt Piper No.2 plants trip
9	4,350	15,800	Bayswater + 1 unit each from Mt Piper, Gladstone, Tarong and Yallourn plants trip
10	5,500	19,600	Equivalent to: Eraring + Bayswater plants trip
11	6,000	14,000	Double tower contingency (4 circuits) of 6 GW REZ.
12	2,500	5,250	Single tower contingency (2 circuits) of 2.5 GW REZ.
13	2,000	4,000	CBF event studied in PSCAD™ will also be studied in UFLS studies to determine frequency impact – loss of multiple Loy Yang machines, Valley Power and Basslink.
14	-	-	Loss of multiple Victorian generating units and VNI separation (historical studies only).
15	-	-	Loss of multiple Queensland generating units and QNI separation.
16	-	-	Loss of multiple South Australian generating units and Heywood interconnector separation (historical studies only).

### Additional assessments by NSPs

AEMO is also liaising with NSPs on studies planned by each NSP to assess non-credible risks (including system stability assessment and identification of any required SPSs) as the part of augmentations where required by NER S5.1.8.

## 3.6 Other review tasks

The following activities will also be included in the 2024 GPSRR scope:

- Existing South Australia destructive winds priority risk – assessment of South Australia transfer limit during destructive wind conditions following PEC Stage 1 commissioning and inter-network testing.
- A summary of key emergency under frequency management initiatives underway in each NEM region.

- A summary of recent SCADA failures and associated Market Suspension events in mainland NEM regions<sup>10</sup>.
- An overview of key operational risks such as those that may arise with the retirement of thermal power stations.
- Consideration of potential requests for, and benefit of, declaration of new protected events, as well as an update on AEMO's review of the protected event framework.
- A status update for the recommendations from the 2023 GPSRR<sup>11</sup> and previous risk reviews.

---

<sup>10</sup> See <https://aemo.com.au/en/energy-systems/electricity/national-electricity-market-nem/nem-events-and-reports/market-event-reports>.

<sup>11</sup> See [https://aemo.com.au/-/media/files/stakeholder\\_consultation/consultations/nem-consultations/2023/draft-2023-general-power-system-risk-review/2023-gpsrr.pdf?la=en](https://aemo.com.au/-/media/files/stakeholder_consultation/consultations/nem-consultations/2023/draft-2023-general-power-system-risk-review/2023-gpsrr.pdf?la=en).

## 4 Models and study case scenarios development

Model and data requirements for 2024 are discussed in this section of the approach paper. For the assessment of non-credible risks, it is important that updated models of relevant systems are included in the studies, or appropriate assumptions be made where information is unavailable. The GPSRR model requirements are summarised in subsequent sections.

Consistent with the 2023 GPSRR modelling approach, a combination of a PSS®E simplified NEM network model, a PSS®E full NEM network model and a PSCAD™ wide-area/four-state model will be used to assess the priority risks identified for the 2024 GPSRR. Further details of these network models are included in Section 4.3.

As detailed in Section 4.7, a potential improvement to the modelling of power system risks since the 2023 GPSRR will be the method used to integrate UFLS. If available at the time of study, UFLS Operations and Planning Data Management System (OPDMS) bus mapping information will be used to identify and model UFLS loads for all mainland NEM regions.

### 4.1 Monitored parameters

The 2024 GPSRR studies will consider the following system parameters when assessing the response of the power system for each priority risk:

- Violation of voltage and frequency operating standards.
- Performance of generators, FRT of the IBR units (specifically in PSCAD™ studies) and DPV disconnections.
- Adequacy of EFCS relevant to the contingency.
- Voltage, frequency, and transmission line flow instabilities.
- Indications in the results towards insufficiencies in system strength or inertia.
- High rate of change of frequency (RoCoF) conditions.

### 4.2 Study software

AEMO will use both PSS®E and PSCAD™ software to assess the contingency events. Where FRT behaviours of IBR might impact the assessment results, events will be studied in PSCAD™. Other events will be studied using PSS®E.

## 4.3 Network model

PSCAD studies – Risk 1 (circuit breaker failure event in Latrobe Valley leading to Basslink instability)

Consistent with the System Strength Requirements Methodology<sup>12</sup>, to assess contingencies relating to system strength issues or FRT behaviours of IBR, AEMO will conduct EMT analysis using the four state NEM PSCAD™ version 5 model. The key system parameters that will be considered in setting up the study cases are included in Table 6. All studies will assume a system normal network configuration<sup>13</sup>.

PSS@E full NEM model studies – Risk 2 (Non-credible loss of double circuit HumeLink 500 kV lines)

Five-year ahead (2028-29) studies for the non-credible loss of double circuit HumeLink 500 kV transmission lines will be carried out by AEMO, in collaboration with Transgrid, using a full NEM network model based on OPDMS cases. This model will be modified to include the new interconnectors, generation and network augmentations that are planned for completion by June 2029 (refer to Table 1 in Section 2.2). As detailed in Section 4.10, future dispatch conditions will be based on the five-year 2022 ISP *Step Change* projection data. The key system forecast parameters that will be considered in setting up the study cases are included in Table 7 (in Section 3.5). Future studies will assume a system normal network configuration<sup>13</sup>.

PSS@E simplified model studies – UFLS screening studies

The UFLS screening studies (Risk 3) detailed in Table 8 (in Section 3.5) will be assessed against both historical 2022-23 and future 2028-29 operating conditions. For the assessment based on historical conditions, AEMO will use a simplified NEM network model of the current system and select historical dispatches from FY 2022-23 representing operating boundaries relevant for each contingency considered. Five-year ahead (2028-29) studies for UFLS adequacy will be carried out using a simplified NEM network model which includes the Queensland – New South Wales Interconnector (QNI) Minor upgrade and Project EnergyConnect Stage 2. As detailed in Section 4.10, future dispatch conditions will be based the five-year 2022 ISP *Step Change* projection data.

Importantly, the use of a simplified NEM model will enable the assessment of a wider range of future dispatch scenarios and contingencies. The performance of this simplified NEM network model was previously benchmarked against results of studies completed for the previous 2022 PSFRR using a modified full NEM OPDMS model as part of the 2023 GPSRR<sup>14</sup>.

The key system forecast parameters that will be considered in setting up the study cases are included in Table 8. All UFLS studies will assume a system normal network configuration<sup>13</sup>.

Assumptions and limitations of the simplified NEM model

For the simplified NEM model, the following network configuration and modelling approaches will be used:

<sup>12</sup>See [https://aemo.com.au/-/media/files/electricity/nem/security\\_and\\_reliability/system-strength-requirements/system-strength-requirements-methodology.pdf?la=en](https://aemo.com.au/-/media/files/electricity/nem/security_and_reliability/system-strength-requirements/system-strength-requirements-methodology.pdf?la=en).

<sup>13</sup> System normal snapshots restore the nominal configuration of the network. Network outages (planned or unplanned) are restored to the nominal configuration while generation and load are retained as they were in the snapshot timestamp. In the future studies the load a generation will be redispatched, and network projects will be added to match the forecasted network conditions.

<sup>14</sup> See [https://aemo.com.au/-/media/files/stakeholder\\_consultation/consultations/nem-consultations/2023/draft-2023-general-power-system-risk-review/2023-gpsrr-appendices.pdf?la=en](https://aemo.com.au/-/media/files/stakeholder_consultation/consultations/nem-consultations/2023/draft-2023-general-power-system-risk-review/2023-gpsrr-appendices.pdf?la=en).

- Each mainland region will be represented by a common high voltage bus (New South Wales, Victoria and Queensland 330 kV and South Australia 275 kV buses). All the lumped regional generators will be assumed to be connected to these regional common buses through appropriate generator transformers.
- Regional generators will be lumped as steam, gas, hydro, wind and solar with appropriate generic models such as alternator, voltage controller, governors and IBR controllers included to the lumped generators according to each generator type.
- UFLS and underlying DPV will be grouped according to their frequency trip bands and connected at medium voltage (MV) buses.
- The grouped UFLS and DPV feeders will be also connected to common high voltage buses through appropriate transformers.
- Interconnectors (aside from Victoria – New South Wales Interconnector (VNI)) will be modelled as per OPDMS network with compensating devices, such as reactors, capacitors and static VAR compensators (SVCs).
- For the future 2028-29 studies, Project EnergyConnect Stage 2 (and the associated SPS) will be included based on the latest planning information available (at the time of study).
- The high voltage (HV) network between South East Switching Station (SESS) and Moorabool Terminal Station (MLTS), and between Red Cliffs Terminal Station (RCTS) and Buronga, will be modelled as per OPDMS network.
- South Australia generators and generators connected between Heywood Terminal Station (HYTS) and MLTS will be modelled as per OPDMS including their dynamic models.
- Alcoa Portland (APD) network loads will be modelled as per the OPDMS.
- The South Australian OFGS generators will be modelled as per OPDMS generator models for the respective plants along with their OFGS trip settings.

Even though the simplified network can capture frequency variations with reasonable accuracy, it is impacted by the following limitations:

- The model excludes actual network impedances, therefore it will not accurately predict power system voltages.
- The model is an approximation of FRT characteristics of IBR plant.
- The model is an approximation of the voltage-based tripping behaviour of DPV.
- The power swings on interconnectors and their angular stability predictions may be optimistic when compared with the full NEM OPDMS model.

## 4.4 Primary frequency response (PFR) governor models

### PFR applied settings

PFR settings data applied to the generators are required to model generator frequency performance accurately. These settings are available to AEMO and have been included in the model.



### Governor models for units with no governor model available in OPDMS

Where generating units have implemented new PFR settings, the updated governor models are not made available to AEMO (in the majority of cases). To address this, AEMO has developed three generic governor models corresponding to steam, hydro and gas turbines which represent governor response in line with new PFR settings during frequency events. These generic governor models will be used for 2024 GPSRR studies, consistent with the 2023 GPSRR modelling approach.

### Governor models for units with governors in OPDMS

Generators have an ongoing obligation to provide NSPs and AEMO with up-to-date modelling information which encompasses all control systems that respond to voltage or frequency disturbances on the power system. AEMO has sent reminders to all large mainland NEM generators of their obligations to provide updated frequency control models, and the need for this information to support the GPSRR. Where updated site-specific information is not available, generic governor models with appropriate PFR settings will be used.

### BESS models

For future committed projects where specific models of BESS are not available, suitable generic BESS models will be used with some assumed frequency droop settings.

### IBR models for large-scale wind and solar generation

The following approach will be used for modelling of IBR in the GPSRR studies:

- For those IBR units that have completed PFR commissioning, where appropriate, the generator supplied model represented in OPDMS will be used.
- Generators have an ongoing obligation to ensure that the NSP and AEMO have accurate models that reflect the voltage and frequency performance of their plant, and it is assumed that the provided models are representative of their actual performance.
- Legacy IBR plants represented in OPDMS as negative loads will be represented using generic PSS®E IBR models.
- For future studies, committed plant will be modelled using generic models with minimum PFR settings.

## 4.5 Frequency control ancillary services (FCAS) response

Unless stated otherwise, FCAS response of synchronous generators will not be considered in the studies apart from the frequency responses provided by PFR governors. The FCAS lower capabilities of IBR will be considered according to PFR settings, if PFR commissioning is completed. The FCAS lower capability of IBR plants will not be considered if confirmation of frequency control enablement from the generator is not available at the time of the study.

## 4.6 Special protection scheme (SPS) models

Typically, for most simulation studies that involve assessment of credible contingency events, SPS models are not included. Given the criticality of such models in the assessment of power system security in response to non-credible contingency events, key SPS models will be considered in the studies, as outlined in Table 10.

Apart from the SPS models in Table 10, additional system protection schemes relevant to key study contingencies will also be modelled.

For the 2024 GPSRR studies, if any updated SPS model/relay models are not available, the latest SPS models available at the time of study or appropriate study assumptions will be used.

**Table 10 Special protection scheme models to be considered**

Model	Region	Model owner	Implementation	Status
<b>Emergency Alcoa-Portland Potline Tripping (EAPT) Scheme</b>	VIC	AEMO Victorian Planning (AVP)	Fortran	Model being updated following review of the scheme (update by AEMO in progress).
<b>Interconnector Emergency Control Scheme (IECS)</b>	VIC	AVP	Python	Model being updated following review of the scheme (per 2020 PSFRR recommendation) (update by AEMO in progress).
<b>System Integrity Protection Scheme (SIPS)/ Wide Area Protection Scheme (WAPS)</b>	SA	ElectraNet	Fortran	It is expected that ElectraNet will develop and provide PSS@E and PSCAD™ models of the WAPS scheme.
<b>Central Queensland – South Queensland (CQ-SQ) Wide Area Monitoring Protection and Control (WAMPAC) scheme</b>	QLD	Powerlink	Python	WAMPAC model has been developed. Any changes following studies associated with 2022 PSFRR recommendation 5 are expected to be excluded based on model availability timeframe.
<b>South Australia Interconnector Tripping remedial action scheme (SAIT RAS)</b>	SA	ElectraNet	-	ElectraNet/TransGrid are presently developing the scheme, in consultation with AEMO. Latest scheme settings at time of study will be used.

## 4.7 Emergency frequency control scheme (EFCS) models

### UFLS models

UFLS settings will be based on UFLS data presently available to AEMO.

At this time, AEMO does not have a PSS@E model of UFLS that accurately maps the load and DPV behind UFLS relays to individual buses for all NEM regions. This model is under development at the time of writing this report.

At the time of study, if the UFLS OPDMS bus mapping information is available, the UFLS loads as identified by the mapping will be used to model the UFLS scheme. If bus mapping is not available, UFLS loads will be allocated within relevant region(s), so the net UFLS loads in the region align with the net estimated regional UFLS for the given snapshot. For future scenarios, DPV and underlying demand growth levels based on the 2022 ISP forecasts will be used to estimate the amount of UFLS at each frequency band. Additionally, any planned future UFLS remediation measures in NEM regions will be modelled.

## OFGS models

Existing South Australia and Western Victoria OFGS model settings will be used unless the scheme is reviewed and revised settings are available prior to the studies being undertaken.

## 4.8 DER/DPV models

An approach similar to UFLS (see Section 4.7) will be used to model DPV. DPV bus mapping data for all mainland NEM regions is available at the time of writing this report and will be used to model the DER/DPVs in PSS@E at relevant buses. For future scenarios, assumptions will be based on ISP forecasts to project future DPV generation in each region<sup>15</sup>.

## 4.9 Load models

The composite load model (CMLD) will be used to model load response in the full NEM PSS@E GPSRR studies. It consists of six load components at the end of a feeder equivalent circuit, which is represented by a series impedance and shunt compensation. It is intended to emulate various load components' aggregate behaviour. It includes three three-phase (3P) induction motor models (motor A, B and C), a single-phase (1P) capacitor-start motor performance model (motor D), static load components (constant current and constant impedance), and a power electronic load model (constant active and reactive power)<sup>16</sup>. The composite load model structure is shown in Figure 3.

**Figure 3 The CMLD model structure and the implementation of the DERAEMO1 model**

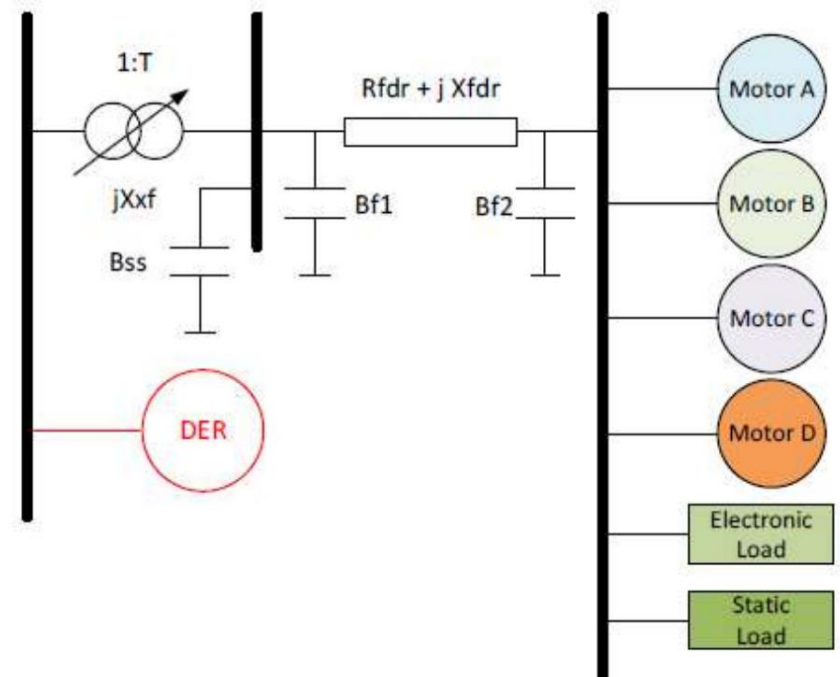

<sup>15</sup> Further details on AEMO PSS@E models for load and distributed PV in the NEM are available at <https://aemo.com.au/-/media/files/initiatives/der/2022/psse-models-for-load-and-distributed-pv-in-the-nem.pdf?la=en>.

<sup>16</sup> See <https://aemo.com.au/-/media/files/initiatives/der/2022/psse-models-for-load-and-distributed-pv-in-the-nem.pdf?la=en>.



The CMLD model captures load shake off in response to large disturbances, which is a significant improvement compared with the previous impedance (Z), current (I) and power (P) ZIP model, which does not represent load shake-off. Since the CMLD model comprises explicit representations of different motor types, the load dynamics due to the response of motors are better captured<sup>15</sup>.

## 4.10 Data to assess future scenarios

To assess contingencies with future network operating conditions, the following five-year 2022 ISP *Step Change* projection data will be applied:

- Regional load (high and low).
- Regional inertia (high and low).
- DER generation (high and low).
- UFLS load availability (high and low).

Note that the future dispatch scenarios selected will be reviewed based on the latest ISP information available following the publication of the Draft 2024 ISP<sup>17</sup>.

## 4.11 Forecasting assumptions

The 2022 ISP forecasting methodology, set out in the 2021 ISP Methodology<sup>18</sup>, will be applied to forecast future network dispatch conditions, noting that the conditions selected will be reviewed based on the latest ISP information available following the publication of the Draft 2024 ISP<sup>17</sup>. The following parameters will be applied to the 2024 GPSRR future projections:

- Short-term schedule half hourly dispatches.
- FY 2028-29.
- High and low demand traces (10% probability of exceedance (POE) and 90% POE).
- Five reference years<sup>19</sup>.
- Three solution iterations, to capture different model probabilistic outcomes, such as generation outages.
- The generation build and retirements in the 2022 ISP *Step Change* scenario.
- Full network constraints representing the network augmentations assumed in the 2022 ISP *Step Change* scenario.
- No units are constrained on for system strength.

---

<sup>17</sup> See <https://aemo.com.au/en/energy-systems/major-publications/integrated-system-plan-isp/2024-integrated-system-plan-isp>.

<sup>18</sup> At <https://aemo.com.au/-/media/files/major-publications/isp/2021/2021-isp-methodology.pdf?la=en>.

<sup>19</sup> AEMO optimises expansion decisions across multiple historical weather years known as “reference years” to account for short- and medium-term weather diversity.

## 4.12 2024 GPSRR model sources

2024 GPSRR model sources are shown in Figure 4.

Figure 4 2024 GPSRR model sources

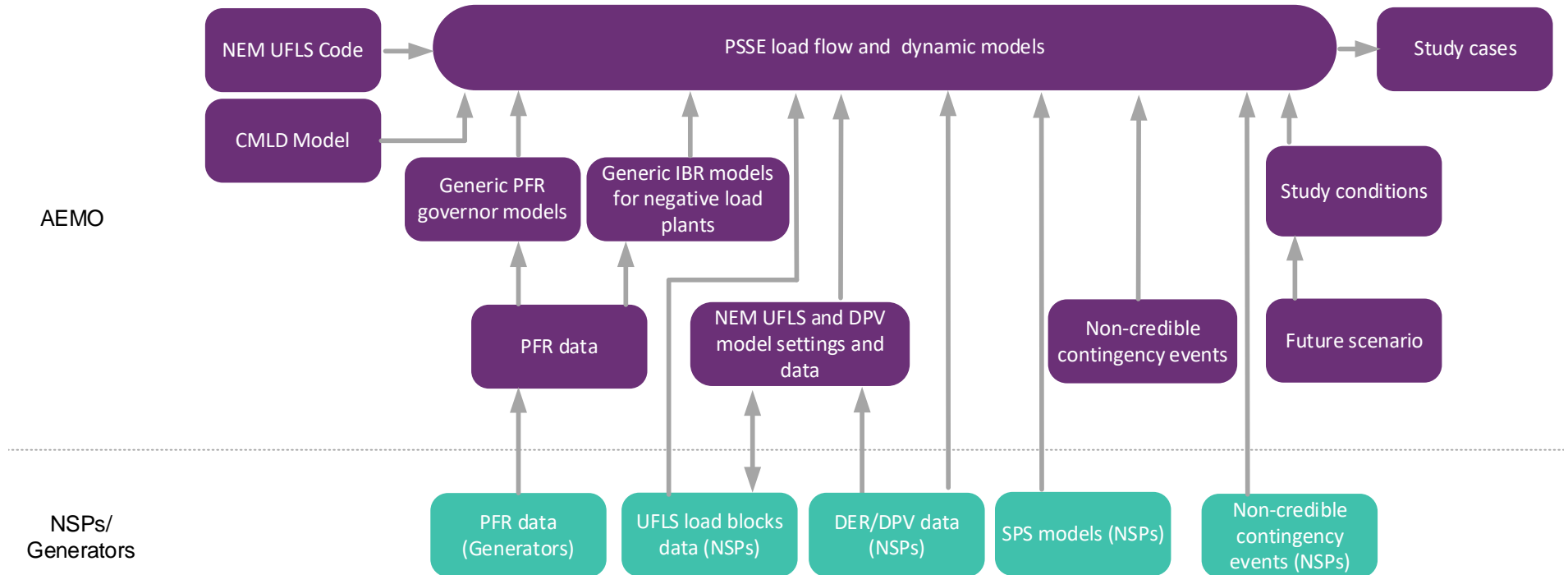

## 5 Risk Cost assessment methodology

This section describes the methodology that will be used in the 2024 GPSRR to estimate the risk cost of each identified risk. The methodology is consistent with the 2023 GPSRR.

This risk cost methodology will be used to quantify key risks in monetary terms. A simplified quantitative approach can be used considering each risk consequence and likelihood as shown below:

$$\text{Risk} = \text{consequence} \times \text{likelihood occurrence (or probability)}$$

The risk cost can be determined by calculating the cost of the risk consequence. The cost of a severe risk will be calculated as the total interrupted of loads (measured in megawatt hours (MWh)) multiplied by the value of customer reliability (VCR)<sup>20</sup> and the estimated time to restore interrupted load following the event (T). The VCR was published at \$43.23/kilowatt hour (kWh) by the Australian Energy Regulator (AER) for year 2019 and it is required to be adjusted to the relevant year where the risk cost is calculating based on the Consumer Price Index (CPI).

The likelihood of a severe risk event has two components:

- Probability of the risk event (Pc), which can be determined using the historical data; and
- The probability of network conditions, which, in combination with the risk event, cause the consequence to occur (Pe). Detailed power system studies combined with dispatch forecasts are required to determine Pe.

Therefore, the above formula can be expanded to:

$$\text{Risk cost} = L \times T \times \text{VCR} \times P_c \times P_e$$

Where:

L is the MW loss (interrupted) due to a non-credible contingency

T is the time to restore the interrupted loads following the event

VCR value of the unserved energy during the interruption

Pc is the probability of a risk event

Pe is the likelihood of the network condition is exposed to a consequence following a non-credible event.

<sup>20</sup> AER 2019, Values of Consumer Reliability – Final Decision, Table 5.22, at <https://www.aer.gov.au/system/files/AER%20-%20Values%20of%20Customer%20Reliability%20Review%20-%20Final%20Report%20-%20December%202019.pdf>.

## 6 Consultation approach

Key consultation activities and tentative timelines planned for the 2024 GPSRR are below.

### Complete

1. Engagement with AEMO internal teams and NSPs to finalise the scope of 2024 GPSRR, including discussions with NSPs in finalising the list of contingencies to be included in the study (May 2023 to July 2023).
2. Seeking NSP and JSSC feedback on the 2024 GPSRR draft approach paper (July 2023 to August 2023).
3. Industry consultation on the 2024 GPSRR draft approach paper (22 August 2023 to 20 September 2023).
4. GPSRR approach industry briefing session (15 September 2023).
5. Publication of the 2024 GPSRR final approach paper (17 November 2023).

### Planned

6. On completion of the studies, AEMO to share the findings with NSPs (January 2024 to March 2024).
7. Seeking feedback from NSPs on the draft 2024 GPSRR report (mid-April 2024 to late-April 2024).
8. Draft 2024 GPSRR report published for industry feedback (May 2024).
9. Publication of the final 2024 GPSRR report (by 31 July 2024).

# Abbreviations

Abbreviation	Term	Abbreviation	Term
<b>1P</b>	single phase	<b>NSP</b>	network service provider
<b>3P</b>	three phase	<b>OFGS</b>	over frequency generation shedding
<b>APD</b>	Alcoa Portland	<b>OPDMS</b>	Operations and Planning Data Management System
<b>AVP</b>	AEMO Victorian Planning	<b>PEC</b>	Project EnergyConnect
<b>BESS</b>	battery energy storage system/s	<b>PFR</b>	primary frequency response
<b>CB</b>	circuit breaker	<b>POE</b>	probability of exceedance
<b>CMLD</b>	composite load model	<b>PSCAD™</b>	Power System Computer Aided Design
<b>CQ-SQ</b>	Central Queensland – South Queensland	<b>PSFRR</b>	Power System Frequency Risk Review
<b>DER</b>	distributed energy resources	<b>PSS®E</b>	Power System Simulation for Engineering
<b>DNSP</b>	distribution network service provider	<b>QNI</b>	Queensland – New South Wales Interconnector
<b>DPV</b>	distributed photovoltaics	<b>QREZ</b>	Queensland Renewable Energy Zone
<b>EAPT</b>	Emergency Alcoa-Portland Potline Tripping	<b>RAS</b>	remedial action scheme
<b>EFCS</b>	emergency frequency control scheme	<b>RCTS</b>	Red Cliffs Terminal Station
<b>EMT</b>	electromagnetic transient	<b>REZ</b>	renewable energy zone
<b>FCAS</b>	frequency control ancillary services	<b>RoCoF</b>	rate of change of frequency
<b>FRT</b>	fault ride-through	<b>SAIT</b>	South Australia Interconnector Tripping
<b>FY</b>	financial year	<b>SCADA</b>	supervisory control and data acquisition
<b>GPSRR</b>	General Power System Risk Review	<b>SESS</b>	South East Switching Station
<b>HV</b>	high voltage	<b>SIPS</b>	system integrity protection scheme
<b>IBR</b>	inverter-based resources	<b>SISC</b>	System Integration Steering Committee
<b>IECS</b>	Interconnector Emergency Control Scheme	<b>SPS</b>	special protection scheme/s
<b>ISP</b>	Integrated System Plan	<b>SVC</b>	static volt-ampere reactive compensator
<b>IT</b>	information technology	<b>TNSP</b>	transmission network service provider
<b>JSSC</b>	Jurisdictional System Security Coordinator	<b>UFLS</b>	under frequency load shedding
<b>kV</b>	kilovolt/s	<b>VCR</b>	value of customer reliability
<b>MLTS</b>	Moorabool Terminal Station	<b>VAR</b>	volt-amperes reactive
<b>MV</b>	medium voltage	<b>VNI</b>	Victoria – New South Wales Interconnector
<b>MW</b>	megawatt/s	<b>WAMPAC</b>	wide area monitoring protection and control
<b>NEM</b>	National Electricity Market	<b>WAPS</b>	wide area protection scheme
<b>NER</b>	National Electricity Rules	<b>ZIP</b>	impedance (Z), current (I) and power (P)